

HAJJ SURVIVAL/REVIVAL
GUIDE:
A Journey Not to Forget or to
take lightly!



Brought to you by:
Nasimco- Youth Networking Desk
Coordinator, Mumdoor Ladak



Preface:

Congratulations on making the intention on ins... going for hajj this year. Indeed you are embarking on a monumental and life altering journey. A journey which too often, many people take lightly due to the fact that they do not understand the true significance of this journey to the Almighty. A journey in which you are walking on the same grounds that the Prophet and Ahlul bayt walked on hundreds of years ago. But yet, we have to ask ourselves, what have we learned from their lives? Are we really the followers of the Ahlul Bayt?

It is not my intention to begin this hajj survival guide on a negative note, however, it is my intention to do my part, in helping you prepare for this journey of a life time.

Unfortunately, in my experience in hajj, I have found that people take for granted that everything on their trip will be taken care of. Yes, of course the flights, accommodations and some of the food will be looked after, however, people get so caught up in these types of preparations, they lose sight of the true meaning behind the hajj. My brothers and sisters, the petty things will take care of themselves, however, what will not work itself out is if you are not spiritually and mentally prepared for what is going to hit you when you are in Mecca and Medina. If you forget sandals or your flashlight, you can easily go and purchase them, but you cannot just get prepared over night for this life changing journey. It's a mindset that you should start many months before you travel to the Middle East, so **THUS PREPARE YOURSELVES ACCORDINGLY!** Read, attend seminars and don't put this down on your priority list. **IT SHOULD BE NUMBER 1!**



The reality is that some people go and do not even understand the order of the rituals performed in hajj, let alone why. However, they were able to approach alims and volunteers in the group to assist them. Unfortunately, this year with the volume of people attending hajj in the organized groups, approaching alims and volunteers for questions may be difficult, so the more you prepare yourselves, the better off you will be because you may find yourself to be helpless at times.

To tell you the truth, the people who attend hajj and do not prepare as much as they should, cannot really be blamed because they simply don't understand how big and monumental this journey is. Furthermore, we don't know whether or not we will be afforded the opportunity to go again, and thus, its best to take advantage of this opportunity and at the end of the trip, there should be no regrets. So prepare yourselves!!!!

CONGRATULATIONS for those of you who have decided to make this next step in your life, and for those of you who have not, ins... this upcoming year you will decide to elevate your position in the eyes of THE MOST GENEROUS, THE ALMIGHTY AND ONE GOD!

Format:

As you may have noticed, there is no Table of Contents for this guide and this has been done for a specific reason; for you to read the entire guide. **Please Note:** *This is only a GUIDE, and does not replace all the work you have to do. The goal of this publication is to outline in a concise format how and where to begin and some things to ponder over in your readings on hajj. If YOU HAVE NOT STARTED READING AND DOING RESEARCH, YOU WILL BE LOST READING THIS GUIDE. THE PREREQUISITE FOR THIS GUIDE IS THAT YOU HAVE ALREADY DONE SOME PRELIMINARY READING. THIS GUIDE IS SPECIFICALLY FOCUSED ON THE SPIRITUAL DIMENSIONS OF HAJJ, AND NOT ON THE RULES.*

Why this Guide???

With the amount of income that the younger generation is earning, the Youth Networking Desk of Nasimco feel that it is our responsibility to encourage people, especially the youth of our community, that while they have the strength and knowledge, to embark on this spiritual and life-altering journey; a journey like no other. Being a youth myself, I know that they have every excuse not to go. Yes, some may be legitimate, but people, please remember that time is such a valuable commodity; if lost it is something we can never get back.

When one is in the prime of their life (their youth), they have more energy, more enthusiasm and more charisma. Furthermore, their outlook on life tends to be more of a positive one. Thus my question to these youth is then WHY WOULDN'T YOU WANT TO GO IN THE PRIME OF YOUR LIFE???

However, this guide is also for anyone who is contemplating the thought of making this immaculate journey. We feel that this concise guide will pull you in the right direction towards that "right path"

We hope you enjoy this guide as much as we enjoyed putting it together. Any thoughts, comments or suggestions are always appreciated and can be sent to the following address:

youth@nasimco.org

If you do get the opportunity to go for hajj, please do not forget us in your duas, and please circulate this guide to as many people as possible.

With Many Salaams and Duas,

Mumdoo (Mohamedhusein) Ladak

Coordinator, Nasimco-YND

September, 2006





WHY GO???

If your goal is to follow in the foot steps of the Prophet and his immaculate household, then here are just a few of the benefits they suggest on making this journey:

Holy Prophet: *“O Ali, anyone who delays Hajj until he dies, Allah will raise him as a Jew or Christian on the day of Judgment.”*

Are you one of these people. The choice is yours!

It is narrated through a second chain from Abu Abdillah, that a desert Arab met the Prophet and said to him, *“O Messenger! I had come out for hajj, but I was delayed. Now, I am a man of means, so instruct me on what I must do in order that I may attain what the pilgrims will attain.”* The Prophet then turned to the man and said *“Look at the mountain of Abu Qubays; If you possessed gold equivalent to that and gave it all away in the way of God, you would still not attain the rewards that the pilgrims will receive. For the one who performs the hajj, from the moment that he begins to prepare for the journey, he doesn’t lift or put down a single thing except that ten acts of virtue are written for him and ten of his sins are forgiven and he is elevated ten degrees.”*

Imam Ali: *“...people gather around it to satisfy their longing for faith and religion as animals gather around a watering hole –a place to satisfy their thirst...People collect at this house of God to obtain hope and peace of mind and to find refuge from sins and vices....Allah has selected those who listen to his commands and obey them, who testify to his orders and come to stand at places*

where prophets have stood...the house of God is a place where people can find rest, peace and hope.

- *"Hajj and Umrah remove poverty and cleanse sins."*
- *"The intention of Hajj opens the gates of God's mercy."*
- *"Allah has made obligatory upon you...The pilgrimage (Hajj) for it consolidates faith."*

Do you want God's mercy? Then go and come back as a brand new person!

Imam Ali: *"For four months afterwards, no sins of a hajji are recorded, and virtues are written for him, unless he commits a major sin."*

Imam Muhammed-e-baqir (A.S): *"When a man intends to go on Hajj, for every step he takes in preparing for his journey Allah will write ten good deeds for him and will write off ten of his wrongdoings and will elevate him ten scales until he completes his preparatory affairs."*

Imam Jaffer-e-Sadiq (A.S): *"When you intend to go on the Hajj pilgrimage, empty your heart for the sake of Allah, Glorified is He, of any preoccupation, which makes you unmindful of Him...Say farewell to the world, comfort and people."*

"Whoever performs the Hajattu'l Islam, has opened a knot of hellfire that was around his neck; and

"Then be prepared for Hajj like one who has no hope of returning home. Behave well with the co-travellers. Observe prayer timings and the traditions of the Holy Prophet (SAAW), perform what is your duty on courtesy, patience, tolerance, gratitude, compassion, generosity, and self-sacrifice all the time."

We are the Shia of Jafferries! Listen to the advice he gives us!

- Lose yourself and never come back
- Turn away from the useless repetition of our everyday life.

- We lead a life in which we have no real progression as human beings.
- We are so focused on the materialism of this world, we lose the focus on why we are really here!
- Look at us and what we have become. We are the same creatures who Allah made the angels bow down to! Are we worthy of this respect?

“Allah is in the hearts of the believers”
(Prophet Muhammad).

“Get rid of whatever keeps you away from Allah’s remembrance and obedience to Him.” (Imam Jaffer Sadiq)

“The performers of Hajj and Umrah are Allah’s guests. If they ask, they will be given, if they pray, they will be answered, if they intercede, their intercession will be accepted, if they keep silent, they will be blessed, and they will be given a million dirhams for each one they have spent. However, not all Hajj pilgrims are equal in terms of reward.

There are 3 types of Hajj pilgrims who return home, and their reward is based on their niyyat:

- 1) *One pilgrim goes there with the pure intention to please God, to ascend to heaven, and to loosen the chains of captivity of “self” so that he will be not be trapped by Satan into going to Hell. Such a man will be rescued from the fire forever.*
- 2) *Another pilgrim goes on Hajj for the sole reason to discharge his religious duty without paying attention to the spirit of the act or removing vices from his self and obtaining virtues. Thanks to Hajj, his sins will be forgiven but since he has not been purified, he has to be careful about his future so that Satanic temptations and his carnal desires will not push him to sins hence fire.*
- 3) *The third man goes on Hajj to escape people’s blame, to get the title of Hajji, and to gain business profits. The reward of such a man is only material and worldly. His family and wealth are secure until he comes back home.”*

(Imam Jaffer Sadiq)

- **Now which group are you going to be a member of??**
- Just like any machine, it needs a tune-up, and hajj is our kick start to realize what success in this world REALLY is about.
 - **In this journey attain khulus (sincerity) in action. Do everything for Allah only, and not to show the people.**
 - **Hajj is to thank Allah. The way one shows appreciation to their friends is by going to their place of residence personally, and saying thank you to them. In this same way, you are going to the house of the almighty to say thank you to him for all the bounties he has blessed you with, and go to his house and say thank you to him personally and start a relationship with him. IT IS YOUR DUTY!**
- **When a friend comes from far to visit you, you go out of your way to show them wonderful hospitality, and try to serve their every need. In the same respect the almighty has nothing to take from you when you are traveling so far to come and visit him. HE HAS ONLY TO GIVE YOU!**
- Lose yourself and never come back – DIE, and return a new person.
 - Clear your debts
 - Make your will
 - Ask everyone for forgiveness
 - Turn away from the useless repetition of life, and turn away from yourself.

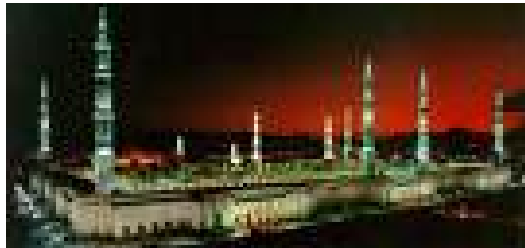

MEDINA:

- The Prophet told Imam Hussein that *"whenever someone visits me, your father, your mother, your brother or yourself, it then becomes WAJIB upon me to visit them on the Day of Judgment and save him/her of his/her sins.*
- Remember that you are now entering the city where the Prophet lived. Do you know anything about the Prophet? Would you let someone into your house, who you did not know? Thus, why should the Prophet let you enter his house?
- Just think and reflect as you read the Izneh Dhukuhi (permission to enter), that you are now standing at the door of the Prophet. What have you done to offend him and his family? Do you think he would be pleased to see us when he comes to answer our call?
- Say Sorry to him, for his advice that he fought for, for so long we have taken lightly. Talk to him, for he is there!!!! He hears us and he is returning our salaams, but the veil we have over our ears is preventing us from hearing it.
- In the permission to enter, you are asking him to give you an entrance as he did to his friends, however, we are not deserving of it.
- As you enter, enter with your right foot and then say the dua "I enter with the way of Allah, and his religion so

forgive me, have mercy on me and I turn to you therefore turn to me.”

- Upon entering this holy place recite 100 times Allahu-akber.
- Remember, that the best act of ibadaat you can do here is to recite as many namaz as possible.
 - Namaz for the salaams of the masjid
 - Namaz for shukr to Allah
 - Namaz for Ziarat of the Prophet (SAWW) and Bibi Fatemah (AS).
 - Qazah Namaz
 - Namaz-e-Shab



Namaz:

- The one who is more overwhelmed by egoism, egotism, self-conceit and selfishness, the farther he will be from the human perfection and from the nearness of the presence of Allah.
- Learn the Namaz properly, and understand its meaning.
- Namaz is like the poles of a tent, and the tent represents the rest of our deeds. Without the Namaz, everything else falls.
 - The acceptance of the salat is conditioned by the presence of heart.
- Pay attention to Namaz, for it is our Mer'aj.
- “The mother of the idols is the idol of ourselves.”
- “Whoever performs a two-rak’at salat without paying attention to any worldly matter, Allah will forgive him his sins.”
- “No part of the salat is yours except the part which you perform with an attentive heart.”
- So when you perform your salaah turn with your heart to Allah.

• When you pay attention to your namaz, Allah will pay attention to you.

- Sit in the mosque and ponder the fact that this is the place our Prophet (p) use to walk on with his daughter, his best friend (Imam Ali) and their children. We have now been afforded the opportunity to come to the same place they have walked on!!! **What a privilege and an honor!**



- Ponder and reflect over the fact that this is the place where Imam Hussein and his family came before they left for Kerbala. We now have this same opportunity.
- This is the place where Hazarat Isa will also be buried.
- This is place that our present Imam comes to visit as well. He could be sitting right beside you? What would you say to him?

MOSQUE OF THE PROPHET (Please see map of the mosque):

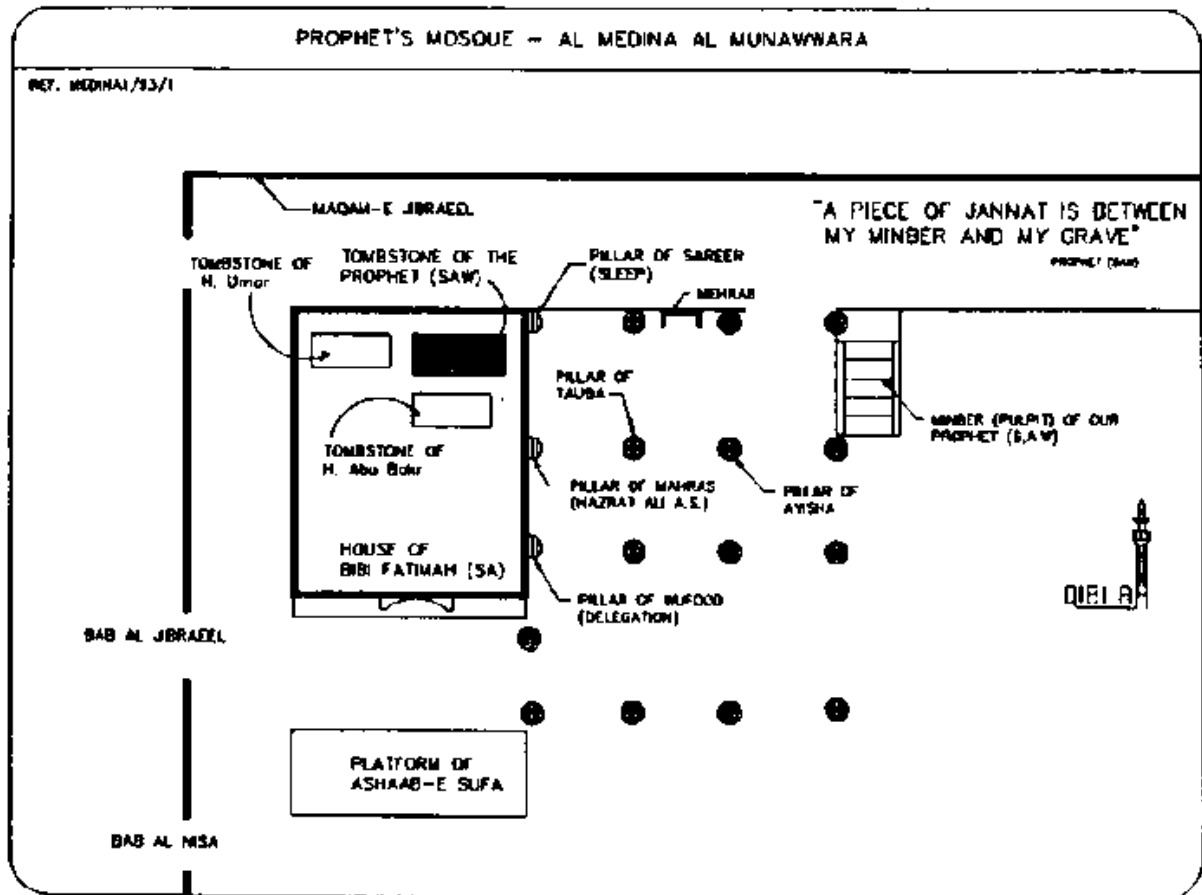

Bab-e-Jibra'el – This is the door through which Hazrat-e-Jibra'el used to enter the chamber of Janabe Fatemah Zehra.

Maqam-e-Jibra'el – Hazrat-e-Jibra'el always used to come to the Prophet of Islam with a revelation through that door.

Riyadul Jannah – It is narrated from Prophet Muhammad (p) that a piece of Jannat is between his mimber and his Zaree. Some historians say that Bibi Fatema (a) is buried there. It is also said that the Prophet (p) of Islam was heard saying that this piece of land would be raised to meet Jannat on the Day of Judgement.

Mimber-e-Rasul – Situated to the West of the Prophet's Zaree is the Mimber-e-Rasul. This is the same mimber that the holy Prophet (p) used to give speeches from.

Mehrab-e-Nabawee – In between the Prophet's Zaree and the Mimbar-e-Rasul is the Mehrab-e-Nabawee. It is from this Mehrab that the Prophet of Islam used to lead Salaat-e-Jamaat.

Pillar of Hannana – Adjoining Mehrab-e-Nabawee is the pillar of Hannaana. The Prophet (p) of Allah used to lean against a date palm tree, that used to be at that spot, to give Khutba. After the Mimber was built, however, the Prophet (p) used the mimber for giving khutba. The date palm tree complained and cried. The Prophet of Islam reassured the date palm tree that it would accompany the Prophet in Jannat. The pillar of Hannana was erected where the tree used to stand.

Pillar of Tawba – The pillar, just North-West of Kabre Mubarak of Prophet (p) and, between the Kabre Mubarak and the Mehra'ab of Rasul is the Pillar of Tawba. It is narrated that Abu Labbaaba spied on the Prophet of Islam to leak the command of Allah (SWT) about the death sentence for Jews in Medina who connived against Islam to kill all Muslims during the battle of Khanda'ak. Abu Labbaaba then repented for this mistake he came to Masjid-e-Nabawee, tied himself to a date tree, and cried desperately for forgiveness. One day when the Prophet of Allah was resting in the residence of Umme Salma, Hazrat-e-Jibra'el came with the ayah of the Quran which mentions the forgiveness of Abu Labbaaba. The Prophet (p) untied Abu Labbaaba and gave him the good news that Allah had forgiven him. A pillar was erected at the same location and it is recommended that one should pray two Rakaat Salaat and ask for forgiveness near that pillar.

Pillar of Mahras: - This pillar stands where Imam Ali (a) used to stand guard over the Prophet (p) of Allah when he slept at night.

Pillar of Wufood – Whenever people from outside Medina came to visit the Prophet (p) he would receive their delegation at the place of this pillar.

Stage of Suffa – This is the stage just North of Prophet’s (a) burial place inside the mosque. The new converts to Islam who were poor and could not afford a place of their own for boarding and lodging used to stay under a shelter built by the Prophet (p) at a place where that stage is located today. Those new Muslims used to come to Medina from different parts of the world. They were housed and fed by the Prophet (p) till they found their own shelter.

Jannatul Baqi:

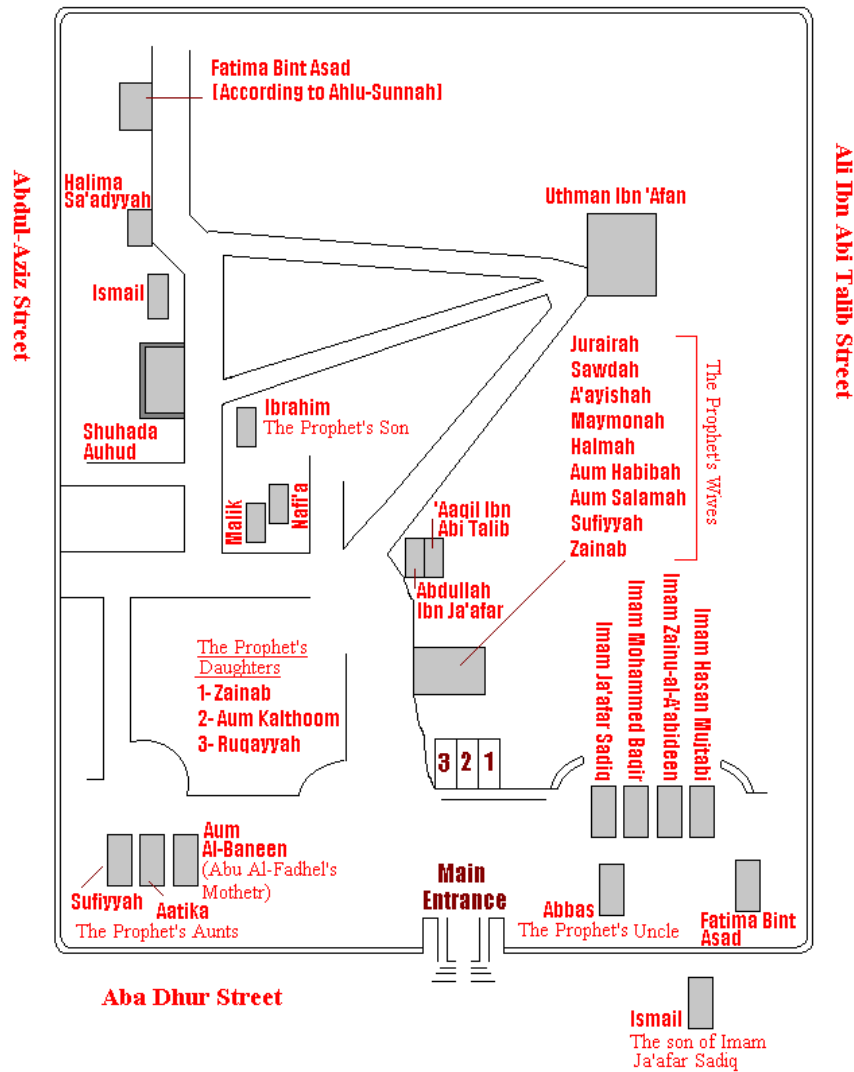

What do you know about the many great personalities that are buried in Jannatul Baqi:

- Bibi Fatemah Zahra (a) – The only daughter of the Holy Prophet(p) according to some historians is buried here.
- Imam Hasan - Our second Imam is the grandson of the Prophet (p), Son of Imam Ali (a) and Bibi Fatema (a), and brother to Imam Hussein (a).
- Imam Zainul Abadeen (a) – Our 4th Imam is the elder son of Imam Hussein (a).
- Imam Muhammad Baqir (a) – Our 5th Imam is the son of Imam Zainul Abadeen (a).
- Imam Jaffer Sadiq (a) – Our 6th Imam is the son of Imam Muhammad Baqir (a).
- Bibi Fatemah Binte Asad (a) – Wife of Abu Talib (a) and Mother to Imam Ali (a), our first Imam.
- Bibi Ummul Baneen (a) – Wife of Imam Ali (a) and mother to Hazarat Abbas (a).
- Bibi Halimah (a) – The Wet nurse of the Holy Prophet (p).
- Ibrahim ibne Muhammad (a) – Son of the Holy Prophet (p) and brother of Bibi Fatemah Zehra (a).
- Ismail ibne Jaffer – Son of Imam Jaffer Sadiq (a).



IHRAM:

- Do ghusl for Ihram, and as you are doing ghusl think about the fact that this water is washing away all your sins, as you are now going to be changing into a “better” servant of Allah.
- You are now putting on the clothes of your death, and this symbolizes you being physically dead. Is there anything you regret not doing before you “die?” This is the time to ponder and think!
- Just think that one day you will really “die” and you will be wearing these exact clothes. Therefore, remember that before you leave, pay all your debts, make your will and ask everyone for their forgiveness. **THE THEME OF IHRAM IS TO REMEMBER DEATH! TAKE THE CLOTHES OF THIS LIFE OFF, AND PUT THE CLOTHES OF DEATH ON!**
- Take the clothes off that represent disobedience and put the clothes of obedience on!
- Then purify yourself with the water of repentance, put on the garment of truthfulness, sincerity, humbleness and modesty.” (Imam Jaffer Sadiq)
- As you wear the Ihram, think about all the things that take you away from Allah’s remembrance.
- Just like the pegs of a tent are used to raise the roof of the tent, Ihram serves as the pillar for the hajj. Therefore it is important to recognize that once Ihram is worn, all focus (just like in namaz) should be on ONLY ALLAH. Free your mind of all the worries of the world, and return back to your creator.
- Whether you are a king, prince, software engineer or a janitor, you are all wearing the same two pieces of clothes just like at your death. Thus, in the eyes of Allah, as you get ready to enter his house, everyone is equal in his “eyes.” Family, Creed, Color, Job, here nothing matters to Allah; only your obedience.



MIQAT:

- Most likely you will be “wearing” your ihram at Masjid Shajarah which is 10 km from Medina. This place is also called Abyar Ali – Ali’s well because he dug a well there with his own hands and gave it for the use of all Muslims.
- Remember that this is the same place where during Mer’aj the Prophet responded to Allah’s call with “Labayk.”
- Think about following in the footsteps of Imam Ali, and making a pledge at this sacred masjid to do something for the benefit of all Muslims.
- This journey is very difficult, however remind yourself of the difficult journey that awaits you from the moment you die to the time you reach the Day of Judgement.
 - If you are beginning to miss your family, remind yourself of the loneliness you will have in the small, dark and narrow grave.
- This is the same masjid that the Holy Prophet and the Imams including our present Imam put on their Imam. **MY BROTHERS AND SISTERS, THE AHLUL BAYT ARE PRESENT!! FEED OFF OF THEIR ENERGY AND THUS AT THIS VERY MASJID, DIG YOUR “ME-NESS” A GRAVE AND BURY IT THERE – FACE THE HEREAFTER, FACE THE TRUTH, AND SHY AWAY FROM THE WORLD OF EVIL!**
- This is the place where bodies are left, but souls become more illuminated! So where the ornaments of Taqwa and Iman!

NIYYAT:

- You are now making a promise to the almighty in the same place where many members of the ahlul bayt have put on heir ihram, that you make an INTENTION TO CHANGE; TO TRANSFORM YOURSELF AND YOUR THINKING FROM "THY SELF" TO "ALLAH!" MAKE A SINCERE PROMISE TO BUILD YOUR SPIRITUALITY.
- The time for niyyat represents that you must now forget about things in your "past life," because this is the beginning of a new beginning.
- Now when you say Namaz, you will be praying with understanding and its true significance because you are making a pledge to him to follow in the footsteps of the Ahlul Bayt.

TALBBIYAH:

- As the servant of Allah, let him know that you are answering his invitation and that you are "here." Do this as the Prophet did when Allah was calling him for the Mer'aj and at this very spot, the Prophet answered "Labayk."
- Let him know that you are there only for him and his pleasure.
- Understand and memorize the talbiyah, and think how fortunate you are, that out of the millions of muslims that are present in the world today, he chose you to come and visit him in his holy house. DO YOU UNDERSTAND HOW TRULY FORTUNATE YOU ARE! NOT EVERYONE GETS THIS CHANCE SO MAKE THE MOST OF IT.
- Once talbbiyah is recited, 25 things become haram in ihram. Understand what they are through your research.
 - You will notice that even halal things become haram, but the question is WHY? This is to train you to leave the pleasures, the joys and the desires of this world and instead, to enter the state of spiritual closeness to Allah. YOU ARE PHYSICALLY DEAD!

“Whoever out of faith and for the pleasure of Allah, utters “Labbayk” seventy times in the state of ihram, God makes a thousand angels bear witness to his freedom from the fire of Hell, and his detachment from hypocrisy. (Imam Ali as.)

BEING IN THE STATE OF IHRAM:

Ayatullah Makarim comments:

“At the time of Hajj, one must distance oneself from bodily pleasures and sinful conduct, because the environment is one of worship, sincerity and detachment from worldly attractions. It is an environment from which the soul must gather strength. It is a place where one must graduate from the material world and step into the spiritual realm that lies beyond.”



ENTERING MASJIDE HARAM, THE KAABA AND TAWAF:

- Keep in mind that you are now entering the precinct of the King of all Kings. Remember that when you were present in your own house, you did not follow his orders and commands. You did not respect his wishes, but yet you are now entering his home. Are you not ashamed to approach him in a sinful state? Would you allow someone who you did not respect to enter your house?
- As you enter this holy house of Allah, remember that this is where the Prophet was mistreated by the kufars, and we are now all following the footsteps of the Prophet. Now understand that after all the hardships the Prophet went

- through, he did it for us, and how are we repaying him? Are we the good muslims that he fought so hard for?
- Also, keep in mind that Imam Ali was born in the holy Kaaba, and we are now ALL doing tawaf around his birthplace! What a fantastic feeling!
 - As you enter the Haram, read the duas in your booklet, and understand the meaning, and the fact that you are here to say thanks to the almighty.
 - You are now entering the house of your host. Pay respect to him and show him how much you have missed him. Talk to him! CRY, CRY AND CRY SOME MORE! Just remember that in order to “see” him, you must be on the right path, and therefore, we must train ourselves to see in the right way!
 - Think about the fact that this is the very place where our current imam is going to rise and establish the government of Islam.
 - Understand the fact that this house represents the house for the people. Therefore it is your home! Allah’s house is your house, because you are from him, it belongs to you, thus, you are no longer a traveler, and Qasr namaz is not required.
 - The Kaaba is the direction we pray five times a day.
 - The Kaaba is the direction which the beds of patients in agony are placed.
 - The Kaaba is the direction we are buried in.
 - *“Whoever looks at the kaaba, rewards are written for him and his wrongdoings are written off until he takes his look away from it.”* (Imam Jaffer Sadiq)
 - Various individuals around the world come and visit the “wonders of the world.” Yet, every year 2 million muslims come and visit a hollow cube made from bricks. No architectural beauty to this building, yet everyone is infatuated with it. WHY? – Because the kaaba is like the sun, and we are like the planets who circumambulate around it, and our mere existence is based on its energy.
 - The way we do tawaf around the kaaba symbolizes the fact that at every action we do, Allah, should be the center of our attention; no one or nothing else should matter.
 - But remember, that you are also circumambulating around a black ethopian slave who was the second wife to Prophet

Ebrahim, and who was left in the middle of a deserted desert just for the pleasure of Allah. DO WE PUT THE SAME LEVEL OF TRUST IN ALLAH, AS BIBI HAJRAH DID?

- Just like the Kaaba, our life is a hollow one inside.
- Kaaba serves as an arrow to lead us in the right direction; it serves as our new beginning.



LEARNING A LITTLE ABOUT THE KAABA AND ITS ZIARAT:

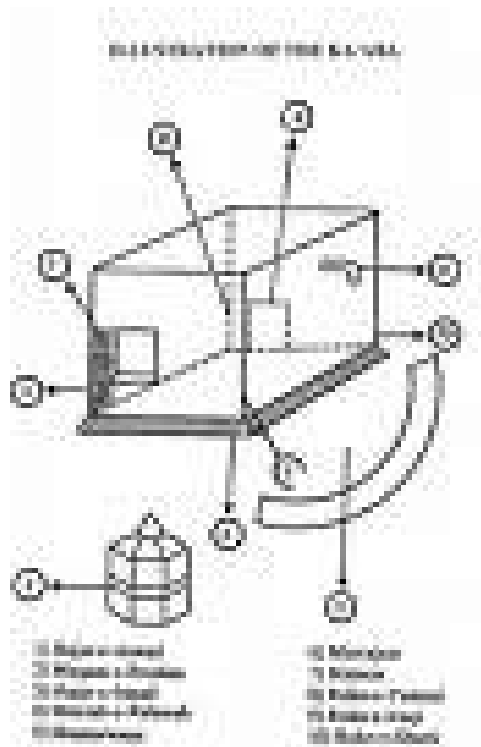

Kaaba:

- The foundations of the Kaaba were first laid by Prophet Adam, and the walls of the Kaaba were raised by Prophet Ebrahim.
- The Kaaba is located exactly underneath Baitul al-Mamoor which is in Janaat.
- The area between Hajr Aswad and the door of the Kaaba (Multazam) was very special to our 3rd Imam, Imam Hussein (a). So please make an intention to go there and be persistent with Allah to forgive all your sins.
- The golden pipe (Meezab-e-Rahmah) was our 4th Imam's favorite spot to go to. It is highly recommended to go there to pray for the birth of children.
- Approximately, 13 meters behind the wall between Rukn Shami and Rukn Yamani is the house of Umme Haani. Umme Hanni was the sister of our 1st Imam and the Prophet use to go to her house to rest after he was done performing tawaaf.
- Approximately, 13 meters behind Hajr Ismail is where the tribal leaders plotted to kill the Prophet, and when they set out for their mission, Imam Ali was found sleeping in the Prophets bed.
- Between Hajr Aswad and Makame Ebrahim is where our Present Imam will be standing with his back facing the Kaaba as he will be accepting the bayat from people, at this very spot!
- Near the corner of Rukn Yemani is where the crack that Bibi Fatemah Binte Asad entered through, to give birth to our first Imam.

Hajr Aswad:

- This is the famous black stone (original color was white) that Prophet Adam use to sit and pray on while he was in heaven.
- This stone was stolen and only the Prophet could place it back in its original position.

- Just like one shakes the right had of a person who they have just made their ally, we must ally ourselves with Allah, and shake his right hand.
- By shaking the hand of the hand of Allah, we are giving him our word that we will follow in the footsteps of the Prophet and his progeny.
- Imam Mahdi will be waiting at Hajr Aswad for people to pledge allegiance to him, when Allah orders him to reappear.
- We are created by the Almighty and thus, on this earth, we are his trustees. ARE WE FULFILLING OUR RESPONSIBILITIES?



Makame Ebrahim:

- This is the block of stone with the footprints of Prophet Ebrahim carved in them as he was building the Kaaba.

Hijr Ismail:

- This enclosure contains the holy graves of Prophet Ismail, Bibi Hajra and many other Prophets including Prophet Hud according to some sources.

Well of Zam Zam:

In search of water for her thirsty baby, Bibi Hajra traveled back and forth from Safa and Marwa. While Bibi Hajra was searching for water, Hazrat Ismail (a), rubbed his feet on the ground due to thirst and because of a miracle of Allah, a water fountain sprang furiously near the feet of Hazrat Ismail (a). Due to the fact that

the water was gushing at such a fast rate, she yelled ZAM ZAM which meant STOP, STOP.



TAWAF:

- Each tawaf represents us tearing down one of the veils that prevent us from seeking nearness to Allah. Thus, list your 7 biggest veils and tear them away! Self-conceit, selfishness, pride, anger, lust, greed, jealousy?
- As you tear each veil you arrive at a state where you do everything in the total submission of Allah.
- *"Allah sends down one hundred and twenty blessings in the precinct of the Kaaba; sixty for those who circumambulate, forty for those who worship and twenty for those who look at it.* (Imam Jaffer Sadiq) **THUS, THE BEST THING YOU CAN DO IN THE HOUSE OF ALLAH, IS TAWAF!**
- Just as the tawaf of the angels around the blessed throne of Allah, is a sign of their love for him, the tawaf of the servants of Allah around the house of Allah, as well is a sign of their love for him.
- Think while you are doing tawaf to Allah, that you are here in front of the door of his house as a beggar, scared to ask him for anything but yet you plead that he protects us from the fire of hell and to give us the sadakah of Janaat!
- If this is your first hajj, remain focused and keep it simple. There are lots of duas to be prayed, but remember that this is a personal journey. As long as you get closer to Allah and improve yourself, you have got the true value of hajj. Don't worry about reading things, because what is the use if you cannot digest its true meaning.
- Please remember that the entire hajj is based on actions, not on rituals. One has to understand why he/she is doing a particular action. Don't be ignorant!
- While you are doing Tawaaf memorize small duas and understand their meaning. You will get more out of the tawaaf this way! Recite the following:

- Tasbeeh ate Arbah
- The Names of Allah
- Recite the dua you do in Qunoot
- Salawaat
- The names of the Imams especially our present Imam



NAMAZE TAWAF:

- When you stand behind Makame Ebrahim to pray your namaz, think if you can be as obedient to Allah as Prophet Ebrahim was. Just think that was willing to give his son up as a sacrifice only for the pleasure of Allah? Can you put your FEET in the shoes of Propeht Ebrahim and give up your most prized possession for the pleasure of Allah? Think to yourself, how have you helped construct the house of Allah?
- The namaz itself is a conversation between you and the almighty, except this time, you are having the conversation in his own house!!! Of course he will listen to you and grant you, your every wish!





SAEE:

- As you perform Sae, recall the story of Bibi Hajra who was alone in the middle of a deserted desert, with a young infant who was thirsty. Why was she there? Simply for the pleasure of Allah.
- As you travel from Safa and Marwa, remember that we are constantly going from Allah's fear (Safa) and his mercy (Marwa) everyday of our lives. Thus read Dua Kumayl on Safa and ask for his rizq and Dua Tawba and Mashloul on Marwa for Istigfar.
- Let this episode in history teach you that one should never sit and do nothing when faced with adversity. Did Bibi Hajra sit and cry when there was no water? NO!! She got up and was running in the constant search to quench the thirst of her baby.
 - She relied on her feet, her will and her mind.
- Sae is physical work. It means exerting your efforts and running after water and bread in order to satisfy your thirst and feed your hungry children. Sae is the struggle and search for your needs out of the heart of nature;
- The Sae teaches us the lessons of self-sacrifice and total dedication to the one and almighty Allah.
- Travelling from Safa and Marwa teaches us that one must struggle in this world to achieve a nice place in the hereafter! If we want to achieve this goal, we have to rely on ourselves to get our mission accomplished!
- Bibi Hajra found the water through her love for Allah, not through search, but it came only after her searching.

Make a list of 3 REALISTIC goals (minimum 3) that you will strive and work hard in achieving after you arrive back from your journey, that will allow you to get closer to the Almighty:

1)

2)

3)

- Remember that people's call upon God is answered only if such a call is from the bottom of their heart, just as Bibi Hajra's was.



THINGS TO DO IN HARAM:

- The best thing you can possibly do in the Haram is to do as many tawafs as possible.
 - Do for the Anbiya and Masumeen
 - For our beloved Prophet
 - For our 12th Imam
 - For the companions of the Prophet
 - For the wives of the Masumeen's
 - For the Mujtahid's
 - For the Shohadda of Islam
 - For your blood relatives
 - For the people who you have done intentional or unintentional zulum on.
 - For the people who have asked you do hajjat for them.
- Make sure that you read the Quran: *"Whilst you are on Hajj, do not neglect Quran as whatever Muslims can achieve is via the Quran. But on your return from Hajj, do not neglect Quran from your daily routine either. Remember how Quran has reached us!!! (Ayahtollah Khomeini)"*



TAQSIR:

- Cut your hair, and bury it. This serves as a reminder that you are here in hajj to become a new person, and the old one should never return, therefore, bury it!!!



ARAFAT:

- You have come all this way to come and visit your Lord, and he is now instructing you to leave his house. The question is WHY? This is Allah telling us that he is closer to us than even our own jugular vein. He is within us and all we have to do is find him. We find him by first finding ourselves.
- Arafat means to gain a deep understanding, a deeper understanding of who we are and what we have become. With this featureless desert, we will understand our Lord and understand his beliefs more clearly. With this realization, we then may be more deserving in returning to Mecca.

- *"The duas of a pious man will be fulfilled in matters regarding this world and the Hereafter, but the duas of an impious man will be fulfilled only in matters regarding this world."* (Imam Muhammad Baqir)
- In Arafat as you find yourself, you understand that this is the place where the creation of man begun. This is the same place where Prophet Adam and Bibi Hawa asked for forgiveness and were granted their wishes. Thus, we should do the same and seek repentance for all our sins.
- At this place, we must pray that Satan no longer tries to push us off the course that takes us towards Allah.
- Arafat is nothing but a plain desert. Nothing to see or witness at this place. Thus, Allah is telling us that here there are no distractions, so think and reflect.
- Think of Arafat as the Day of Judgement, and the sea of white that you will witness!!!
- Just think that the very sand you are walking on is the same sand where the Prophet and Imams gathered to seek khlulus. But they were perfect!!! **See how much work we have to do!**
- Imam Mahdi is present here in Arafat. Pray that he intercedes on your behalf.
- Just as Imam Hussein and all his companions did on the night of Ashura, they spent it in supplication. We should do the same, and seek help from Imam Hussein. .
- Remember, this is the same place where Ebrahim supplicated to Allah and won his favor. **WE CAN WIN HIS FAVOR TOO IF WE HAVE SINCERITY IN ACTION.**

Recommended Actions in Arafat:

- Try to recite the following:
 - First 10 verses of Surah Baqarah
 - Ayat Al-Kursi
 - Surah Tawhid
 - Surah Falaq
 - Surah Nas
 - The last verses of Surah Hashr

- Verses 54-57 of Surah A'raf
- Dua Arafat

The greatest sin for the one who is in Arafat is that he returns believing that God has not forgiven him, that is, despairing of the mercy of God. (Imam Jaffer Sadiq as)

MUZDALIFAH:

- The word Muzdalifah means to “pause.” This “pause” symbolizes that our life is so short, we have to make the most of it, and that is doing everything for the cause and will of Allah.
- This is the place where the army of Abraha was destroyed by birds who brought with them stones from Muzdalifah so that his army was not able to destroy the Kaaba! Therefore, here remember this event and recite Surah Feel.
- *“If you can keep vigil tonight, do it, for it has been reported to us that the gates of heaven are not closed to the believers tonight. Allah says that ‘I am your Lord and you are My servants. You have paid my due. Hence, it is incumbent on Me to answer your prayer.’ Therefore, He removes the sins of whomever He wishes and forgives whom He wills.”* (Imam Jaffe-Sadiq)
- Remember Allah during this pause, so that you will attain intelligence and insight.
- The understanding that you attained while in Arafat must now be transported to your heart by the remembrance of Allah; and from the heart, it must be transported to your eyes, ears, tongue and all other parts of the body until your complete presence is given another life.
- The stop in Muzdalifah is a chance for you to now plan, and strengthen your spirit (to think!), to collect arms and to prepare yourself for the battlefield? WHAT???
- All individuals in Muzdalifah are now the soldiers of Allah – the soldiers to uphold the truth. The stop is for you to collect arms as you prepare to battle your enemy (Satan) tomorrow (in Mina). The biggest Satan is within you!
- Wear the clothes of death and hold the arms, and at the same time think and discover yourself, as to who you want

to be. Remember that the Prophet has said that *"1 hour of reflection is better than 1 year of worship."*

- Each weapon (49 stones) is used to kill the enemy. Who is the enemy? Anything that pulls you away from Allah. Stone your ego to death, anger, jealousy, pride etc.



Mina:

- This is the place where Satan appeared to prevent Prophet Adam from performing his duty with different types of temptations. However, Adam with a hint from Gibrael threw 7 pebbles at Satan in three sites to drive him away. Therefore, drive you Satan away by doing as Prophet Adam did!
- Satan also came to stop Prophet Ebrahim, when he was on his way to offer Prophet Ismael as a sacrifice. Once again, Satan appeared 3 times (at the spots of the Jamarat), and in order to drive him away, Prophet Ebrahim threw stones at him as well.
- *When you are stoning the jamaraats, keep in mind that in answer to Allah's order, Prophet Ebrahim was willing to give up everything - worldly pleasure, wealth and power. When Satan tried to stop him using these three things as excuses to disobey Allah, Prophet Ebrahim drove him away by stoning him. So when you throw the stones, although you are aiming at the pillars that represent the points where Satan appeared to lead Prophet Ebrahim astray, throw them at your "nafs," at you very soul. Aim at the blackness within it which takes you away from Allah – your wealth, your desires, your power over those lesser than you, your*

pride, your arrogance, your constant thinking of ME, ME, I, I. (Ayatullah Milani)

- These pebbles also represent the worldly riches that must be thrown away for the sake of God.
- It is here where the enemy is destroyed, and Satan has been defeated.

Make a list of your 3 (minimum 3) biggest Shaitans (qualities that prevent you from attaining the nearness of Allah, eg. Lieing, Pride, Jelousy etc) and explain as to how you will go about getting rid of these "shaitans" that you will be stoning in Mina?

1)

2)

3)

OURBANI:

- Prophet Ismael was a treasure for his father, Prophet Ebrahim. And now after 3 consecutive dreams (first one was on 8th Zilhajj), he was instructed to slaughter his beloved SON! Thus, Prophet Ebrahim was struggling between Love (which was his life in this world) and truth (which was his faith in Allah). In order to submit to the truth, you must give up all interests which pre-occupy your thoughts and prevent you from communicating with God. **WHO IS YOUR ISMAIL???**
- Go and pray 2 rakaat namaz at Masjid Khif, which is the exact place Prophet Ebrahim was to offer the sacrifice of his son.
- Prophet Ebrahim had to give up the son whom he had prayed so hard for, whom he had seen grow up into an admirable young man. Furthermore, Prophet Ismail who was in the prime of his youth and had everything to live for, willingly walked to the place of his sacrifice. LOOK AT THE EXAMPLES WE HAVE WHO ARE THE TRUE FRIENDS OF ALLAH.
- *Cut the throat of carnal desires and greed by offering animal sacrifice.* (Imam Jaffere-Sadiq)
- *Sacrifice your most beloved thing for Allah, guess what this is!!!! Yes it is ME, ME and ME!!! Until you sacrifice "ME" you cannot abandon worldly things and get close to Allah.* (Ayatullah Khomeini)
- *Sacrifice is a symbol of devotion and offering one's life in the way of the Beloved and the maximum degree of submission to God.* (Sayyid Mohammed Zia Abdi)
- Just think that Prophet Ebrahim was ready to sacrifice one family member and how tough it was. How tough was it for Imam Hussain who gave up his entire household for the pleasure of Allah.



TAQSEER – HALAQ:

- The point of shaving off all your hair (for men only) is to signify that you are now re-born and a brand new individual who is now sinless!!!
- After shaving of ones head, one should then shave the hardness from their heart and correct ones conduct.
- Bury your hair in Mina, and along with hit bury all the things that come between you and the almighty.

THE DELAY IN MINA:

- The delay is for you to think, and reflect about hajj and understand what you have just done.
- This 2-3 day break in Mina allows the Muslims to talk and get to know one another. It also gives them the time to discuss problems and their potential solutions in their respective communities. This MINA, is the biggest conference in the World!!
- The stop in Mina allows you to renew your promise to Allah to destroy all existing idols in the world.

HITTING ALL THREE JAMARAAT:

- Why do you continue to hit all three jamaraat for the next 2-3 days after you have defeated Satan on the first day? This is because Satan may survive even after it has been defeated. Satan is always looking for another way in, so beware!!! He has many colors and many tricks.

OUTSIDE ZIARAT IN MECCA:

Jannat Al-Mualla: This is a cemetery in Mecca that existed from before the time of the Prophet of Islam. Many relatives and companions of the Prophet are buried here. Some of them include the following:

Bibi Khadijatul Kubra – She was the first wife of the Prophet of Islam and mother to Bibi Fatemah (a).

Abu Talib – He was the father of our first Imam, and uncle to the Prophet of Islam.

Abdul Muttalib – He was the grandfather of the Prophet of Islam

Hazrat Abdullah bin Abdul Muttalib – He was the father of the Prophet of Islam.

Hazrat Amina binte Wahab – She is the mother of the Prophet of Islam, and passed away when the Prophet was only 5 years old. However, some historians say that she is buried in a town called Abawa.

Masjide Jinn: A group of Jinn were passing by, when they heard the Prophet of Islam (a) reciting the Holy Quran. They were so moved that they came to the Prophet, repented and accepted Islam. A masjid was later built at that place.

THE RETURN HOME:

The real Hajj begins when you return back home to all the materialism and the distractions. This will be the true test whether or not you learned from the struggles that you incurred on this journey. Did you pay to get closer to the Almighty or did you just pay to get the hardships of the desert? When one returns home this is where they will understand whether or not they have truly changed and become a better person!

- *“The responsibilities at the stage of going from Mecca and Medina back to one’s hometown are much more difficult, since now one’s responsibilities become just like those of the Prophet of Allah.”* (Ayatullah Mazaheri)

- After returning home, the Hajji must teach all that he/she learned in self-building to the ones who did not have the opportunity to go.
- Your speech, actions, manner and disposition must be an example for others, and this is truly the best gift that one can bring back for the rest of the people.
- Start praying the namaz on time, pay khums and wear your hijab. YOU ARE NOW A HAJJI, SO ACT LIKE ONE!!!
- *That woman who has gone to Mecca but returns without the gift of the hijab of Fatimah az-Zahra (as) for others and continues to wear her hijab in a wrong manner, or does not wear the hijab at all, has trampled over more than 10 verses of the Quran and her Hajj was nothing more than troubles to herself.* (Ayatullah Mazaheri)
- *"The one thing that a man and woman who have returned from Hajj must always keep in mind at this stage is that the Hajji's accountability before Allah, the Ahlul Bayt (as) and the people is much different than that of the accountability that the "common people" have."* (Ayatullah Mazaheri)
- *"...that whoever slays a soul, unless it be for manslaughter or for mischief in the land, it is as though he slew all men; and whoever keeps it alive, it is as though he kept alive all men;..."* (5:32, Holy Quran). Imam Jaffer Sadiq explains that if I give life to one person through my speech, acts or performance in propagation (of the religion), then I am like that person who has saved the entire humanity. However, if through my speech, actions or the way I carry myself, I cause even one person to be lead astray, and have reduced the (worth of the) Hajj, and reduced the (worth of the) religion in that person's heart, then I am just like the person who has killed all of those in world.
- *"Every day is Ashura and Every land is Kerbala. Now ask yourself: Are you like the person who continued his tawaf while he (Imam Hussein {as}) went to kerbala? Because the people who continued their tawaf while he went to Kerbala were no better than those who were circumambulating around the green palace of Muawiya."* (Dr. Shariati)

APPENDIX I

PHILOSOPHY OF HAJJ TAUGHT TO US BY THE SIXTH IMAM:

O pilgrims of the Sacred House, come to yourselves, for the heavenly call of the Holy Quran echoes in the ears of our soul: O Couriers of God's House who have taken off your worldly garment and have given positive response to your Lord! O you who stay in Arafat, al-Mash'ar, and Mina! O you who stone Satan to death! O you who sacrifice the animal of concupiscence! O you who remove vices by shaving your head and clipping your nail! O you who renew your pledge with God by caressing the Black Stone! Do not forget your covenant and remember God a great deal! Remember the following Quranic Verse throughout your life:

الْحَجُّ أَشْهُرٌ مَعْلُومَاتٌ فَمَنْ فَرَضَ فِيهِنَّ الْحَجَّ فَلَا رَفَثَ وَلَا فُسُوقَ وَلَا جِدَالَ فِي الْحَجِّ وَمَا تَفَعَّلُوا مِنْ خَيْرٍ يَعْلَمُهُ اللَّهُ وَتَزَوَّدُوا فَإِنَّ خَيْرَ الزَّادِ التَّقْوَى وَاتَّقُوا يَا أُولِي الْأَلْبَابِ.

“The pilgrimage is (performed in) the well-known months; so whoever determines the performance of the pilgrimage therein, there shall be no intercourse nor fornication nor quarrelling amongst one another; and whatever good you do, Allah knows it; and make provision, for surely the provision is the guarding of oneself, and be careful (of your duty) to Me, O men of understanding. (2:197)”

Imam Zaynul-Abidin –Sajjad- (a.s) was received by Shibli when he was back from Hajj and the following dialogue occurred between them:

The Imam: Did you perform Hajj, Shibli?

Shibli: Yes, son of Allah's Messenger, I did.

The Imam: You stopped at Miqat, put off your sewn clothes, and washed yourself, did you not?

Shibli: Yes, I did.

The Imam: As you stopped at Miqat, did you intend to put off the garment of disobedience (to God) and put on a garment of obedience (to Him)?

Shibli: No, I did not.

The Imam: As you put off your sewn clothes, did you intend to get rid of ostentation, hypocrisy, and intrusion in suspicious matters?

Shibli: No, I did not?

The Imam: As you washed yourself, did you intend to wash yourself from sins and offenses?

Shibli: No, I did not.

The Imam: In that case, you did not really stop at Miqat, put off your sewn cloths, and wash yourself. You washed yourself thoroughly, entered the state of Ihram, and intended to perform Hajj, did you not?

Shibli: Yes, I did.

The Imam: As you washed yourself thoroughly, entered the state of Ihram, and intended to perform Hajj, did you intend to wash yourself thoroughly with pure repentance to Allah?

Shibli: No, I did not.

The Imam: As you entered the state of Ihram, did you intend to abstain from every matter that Allah deems unlawful?

Shibli: No, I did not.

The Imam: As you intended to perform Hajj, did you intend to get rid of any pledge that you took with anyone other than Allah?

Shibli: No, I did not.

The Imam: In that case, you did not wash yourself thoroughly, enter the state of Ihram, or intend to perform Hajj. Did you enter Miqat, offer the two-Rakat prayer of Ihram, and say Labbayk (Talbiya)?

Shibli: Yes, I did.

The Imam: As you entered Miqat, did you intend to meet all the qualifications of the visitation of the Sacred House of Allah?

Shibli: No, I did not.

The Imam: As you offered the two-Rakat prayer, did you intend to seek nearness to Allah through the best deeds such as prayers and the deeds by which servants of Allah can obtain His rewards?

Shibli: No, I did not.

The Imam: As you said Labbayk, did you intend to utter any statement of obedience to Allah and shut your mouth against any statement of disobedience to Him?

Shibli: No, I did not.

The Imam: In that case, you did not enter Miqat, offer the two-Rakat prayer of Ihram, or say Labbayk. You entered the Sacred Precinct, saw the Kaaba, and offered prayers there, did you not?

Shibli: Yes, I did.

The Imam: As you entered the Sacred Precinct, did you intend to abstain from backbiting any individual of Islam?

Shibli: No, I did not.

The Imam: As you arrived in Mecca, did you intend to direct towards Allah and no one else?

Shibli: No, I did not.

The Imam: In that case, you did not really enter the Sacred Precinct, see the Kaaba, or offer prayers. You circumambulated the Holy House, touched the corners, and performed the Sa'y, did you not?

Shibli: Yes, I did.

The Imam: As you performed the Sa'y, did you intend to seek refuge of Allah (from the trickeries of Satan and evil temptations) and that He, the Knower of the unseen, knew this from you?

Shibli: No, I did not.

The Imam: In that case, you did not really circumambulate the Holy House, touch its corner, or perform the Sa'y. You caressed the Black Stone, stopped at the standing-place of Ibrahim (a.s), and offered a two-Rakat prayer there, did you not?

Shibli: Yes, I did.

The Imam (a.s) then cried so loudly and said:

To caress the Black Stone is to shake hands with Allah. Look, poor man, do not ever waste the reward for the thing that is greatly sacred and do not breach your caressing by acts of violation (of God's instructions) and seizure of illegal things, just like the sinful.

As you stopped at the standing-place of Ibrahim (a.s), did you intend to stop at every act of obedience (to God) and leave every act of disobedience (to Him)?

Shibli: No, I did not.

The Imam: As you offered the two-Rakat prayer, did you intend to offer the same prayer that was offered by Ibrahim (a.s) and to disappoint Satan?

Shibli: No, I did not.

The Imam: In that case, you did not really caress the Black Stone, stop at the standing-place of Ibrahim (a.s), or offer the two-Rakat prayer there. You came near to Well Zamzam and drank from its water, did you not?

Shibli: Yes, I did.

The Imam: As you did, did you intend to come near to acts of obedience (to God) and cast your sight down acts of disobedience (to Him)?

Shibli: No, I did not.

The Imam: In that case, you neither really came near that well nor did you drink from its water. You roamed, walked, and frequented to Mount Safa and Mount Marwa, did you not?

Shibli: Yes, I did.

The Imam: As you did, did you intend to be between hope and fear (of God)?

Shibli: No, I did not.

The Imam: In that case, you did not really roam, walk, or frequent between Safa and Marwa. You then left for Mina, [\[191\]](#) did you not?

Shibli: Yes, I did.

The Imam: Did you intend to save people from your tongue (words), heart (ill intention), and hand (deeds)?

Shibli: No, I did not.

The Imam: In that case, you did not really leave for Mecca. You halted in Arafat, mounted Jabal al-Rahma (Mount Mercy), recognized Nemira Valley, and supplicated to Allah at al-Mil and Jamarat, did you not?

Shibli: Yes, I did.

The Imam: As you halted in Arafat, did you intend to recognize Allah, Glorified is He, and His knowledge, and recognize that He is holding on the record of your deeds and that He has full acquaintance with your hidden and secrets?

Shibli: No, I did not.

The Imam: As you mounted Jabal al-Rahma, did you recognize that Allah would have mercy upon every believing man and woman and see to every Muslim male and female?

Shibli: No, I did not.

The Imam: As you were on Nemira,^[192] did you recognize that your advices and warnings to people are fruitless unless they are originated from Allah's instructions?

Shibli: No, I did not.

The Imam: As you stopped at al-Alam and an-Nemirat,^[193] did you recognize that these signs would testify for your acts of obedience (to God) and would keep you like the Keeping Angels whose mission is to keep you according to Allah's instructions?

Shibli: No, I did not.

The Imam: In that case, you did not really stop on Arafat, mount Jabal al-Rahma, recognize Nemira, supplicate to Allah, or stop at an-Nemirat. You passed by the Two Signs (al-Alamain)^[194], offered a two-Rakat prayer before so, walked in Muzdelifa, picked up pebbles there, and passed by al-Mash'ar al-Haram,^[195] did you not?

Shibli: Yes, I did.

The Imam: As you offered the prayer, did you intend it to be thanksgiving... that saves from every hardship and alleviates all difficulties?

Shibli: No, I did not.

The Imam: As you walked between the Two Signs without turning to right or left, did you intend not to turn away from the right religious with heart, tongue, or other organs?

Shibli: No, I did not.

The Imam: As you walked in Muzdelifa and picked up pebbles, did you intend to get rid of every act of disobedience and every item of ignorance and to fix in your behaviors every item of knowledge and good deed?

Shibli: No, I did not.

The Imam: As you passed by al-Mash'ar al-Haram, did you intend to carry in heart the slogan of the pious people and the God-fearing ones?

Shibli: No, I did not.

The Imam: In that case, you did not really pass by the Two Signs, offer a two-Rakat prayer, walk in al-Muzdelifa, pick up pebbles there, or pass by al-Mash'ar al-Haram. You reached in Mina, threw the pebbles (i.e. performed the Ramy al-Jamarat), had your hair cut, slaughtered your sacrificed animal, offered prayer in Kheif Mosque, returned to Mecca, and performed Tawaf al-Ifadha, did you not?

Shibli: Yes, I did.

The Imam: As you arrived in Mina and threw these pebbles, did you feel that you achieved your aim and that your Lord would settle all your needs?

Shibli: No, I did not.

The Imam: As you threw these pebbles, did you intend to stone Eblis, your enemy, and challenge him through your precious Hajj?

Shibli: No, I did not.

The Imam: As you shaved your head, did you intend to purify yourself from all filths and liabilities of people that lie on your shoulders, and to get rid of sins as if your mother had just given birth of you?

Shibli: No, I did not.

The Imam: As you offered prayer in Kheif Mosque, did you intend that you would never fear anything except Allah and the responsibilities of your (past) sins and that you would hope for nothing except Allah's mercy?

Shibli: As you slaughtered your sacrificial animal, did you intend to cut off the throat of greed by clinging to the reality of piety, and to follow the exemplary tradition of Ibrahim (a.s) who intended to slaughter his dear son (so as to carry our God's order)?

Shibli: No, I did not.

The Imam: As you returned to Mecca and performed Tawaf al-Ifadha, did you intent to supply yourself with Allah's mercy, return to the obedience to Him, cling to His love, perform all His precepts, and seek nearness to Him?

Shibli: No, I did not.

The Imam: In that case, you neither reached Mina, nor did you throw these pebbles on Satan, nor did you shave your head, nor did you perform the rituals of the Hajj, nor did you offer prayer in Kheif Mosque, nor did you perform Tawaf al-Ifadha, nor did you offer sacrifice for the Lord. Go back, you did not perform Hajj.

As he heard these words, Shibli wept heavily for the shortcomings of his performance of Hajj and decided to perform idea Hajj the next year, and he did. [\[196\]](#)

APPENDIX II

BENEFITS OF DUA: **WWW.DUAS.ORG**

DU-A'A AL MASHLOOL

This du-a'a known as "supplication of the youth stricken for his sin," is quoted from the work of Kaf-ami and from Muhaj al Da-wat by Sayyid ibn tawus.

Through Imam hussain it is reported that one day he and his father, after performing Hajj, caught sight of a paralysed young man crying his eyes out in repentance. They went near to console him and find out the reason of his sorry plight. He was a habitual sinner, always teased his father, disobeyed him and treated him with contempt. One day, disgusted, the father invoked curse upon him. So he was affected with paralysis.

Then and there Ali ibna Talib wrote his dua'a and gave it to him with instruction to recite after Isha salat.

Next day fully cured, as fit as a fiddle, he came to Imam Ali and said that he had recited the dua'a as told and went to sleep. He saw the Holy prophet in the dream. The holy prophet, gently touched his body with his hand and asked him to remember this dua'a as it contain ismi azam (the great name of Allah).

Recite this dua'a after Isha salat. It brings countless blessings. All your legitimate desires will be fulfilled. It drives away poverty and sickness. Sins are forgiven. Debts are cleared. Enemies become friends. Domestic affairs are set aright.

Disputes are settled in your favour. Prisoners are set free mental worries disappear. Prosperity, sound mind and healthy body stand by you at all times.

Mercy and forgiveness of sins are the main advantages the almighty Allah makes available if this dua'a is recited regularly.

Recite it on Fridays.

DU-A'A AL KUMAYL

Imam Ali ibni Talib taught this dua'a to his very close companion, Kumayl ibni Ziyad. Allamah Majlisi says that this dua'a reached Imam Ali through prophet Khizr.

It should be recited during the night of the middle of Sha'-ban and every Thursday night. If not possible recite once a month on any Thursday night, or once in a lifetime.

To seek fulfillment of legitimate desires recite it after obligatory prayers till your desires are fulfilled.

It keeps safe from the intrigues of enemies, multiply means of livelihood, and sins are forgiven.

DU-A'A AL TAWASSUL

Shaykh Tusi says, in his book Misbah, that imam Hassan bin Ali Al Askari wrote this dua'a for Abu Muhammad who requested him to teach him the proper way of reciting

salawat. Allama Majlisi has mentioned this dua'a on the authority of Ibn babawayh who confidently says that there is no difficulty or problem that this dua'a does not solve.

The merciful Allah is beseeched in the name of and for the sake of the Holy prophet and his Ahl ul Bayt.

It is known as "quick-fulfillment-of-all-legitimate-desires" dua'a.

DU-A'A A'DEELAH

This dua'a contains the articles of faith. Every faithful must recite this dua'a regularly to drive away Shaytan, and to remain firm in the true faith.

A dying faithful, in the last moments of life, should recite this dua'a, or , if it is not possible, ask someone else to read it aloud for him or her, so as not to be misled by doubts which may come into the mind, or not to be depressed emotionally, because these forces together with the misleading suggestions of Shaytan, more often than not, in the last hour of life, make man die a death of an infidel or hypocrite.

DU-A'A AL SAMAAT

Shaykh Tusi, Sayyid ibna Tawus and Kafami report that this dua'a, according to Muhammad ibn Uthman Umri, a reliable representative of Imam Sahibuz Zaman, was taught by Imam Muhammad bin Ali Al Baqir and Imam Jafar bin Muhammad Al Sadiq.

Allama Majlisi says that all the pious religious scholars used to recite this dua'a. Shaykh Kafami says that this dua'a contains izmi azam (the great name of Allah). Imam Muhammad bin Ali Al Baqir advised the faithfuls to recite this dua'a as it brings the downfall of the enemies of Ahl ul Bayt.

Imam Jafar bin Muhammad Al Sadiq said that Allah taught this dua'a to prophet Musa to overcome his enemies.

Recite this dua'a daily.

This dua'a is particularly recited after Isha salat of Friday night and after Asr salat of Friday.

It should be recited every Thursday night.

It is the most reliable safeguard against enemies.

To seek fulfillment of legitimate desires this dua'a dua'a is very useful.

DU-A'A YASTASHEER

Ibna tawus in his book Muhaj al Dawat and Kafami in his book Misbah narrate this dua'a on the authority of Imam Ali ibna abi Talib who learned it from the Holy Prophet.

The Holy Prophet advised him to recite this dua'a regularly, whether in prosperity or poverty, till death, because it unveils the secretes of creation and divine strategy. Words can not describe its merits. Intelligent can not describe its meanings. No sooner someone begins to recite it, Almighty Allah send blessings, and his mercy surrounds him, peace and tranquillity descend upon him.

The sound of this dua'a moves to and from around the arsh, its direct destination. All his desired are fulfilled. His needs are taken care of. He gets freedom from wants and is kept safe from hardships and misfortunes. His mind opens up new dimensions of contemplation.

On the day of judgement he will be received by Allah with respect and honour.

It cures insanity if recited before a mad man.

It relives pain of childbirth if recited before the expectant mother.

It recited on forty Fridays consecutively all sins are forgiven.
It cures sickness and disperses sorrows. For him who recites it before going to sleep Allah appoints one thousand angels to pray for him till morning.
He who recites it and dies within 24 hours it treated like a martyr.

AKHAS'SI S'IFAATIKA

It is a small but very compact dua'a. As its meaning tell us the reciter asks for every thing he needs in this world, and will be in need of on the day of judgement.
All pious religious scholars recite this dua'a at the time of tawaf of Ka-bah.

DU-A'A A'Z'MUL BALAA

Kafami says in his book Baladul Amin that if a wrongfully confined prisoner recite this dua'a he will soon be set free.
If a person find himself surrounded by misfortunes or intrigues he must recite this dua'a to come through tight situations, deadlock and crises.
This dua'a is attributed to the living Imam Sahibuz zaman.
It brings immediate help from our living imam.

DU'A'A T'ALABIL H'AWAA-IJ

Imam Ali bin husayn zayn al Abidin is the author of this dua'a.
It is recited on Fridays.
To seek fulfillment of the legitimate desires recite this dua'a at the time of sunset.

DU-A'A A'AFIYAT

Imam Ali bin husayn zayn al Abidin is the author of this dua'a.
It is recited to thank and praise Allah whenever one receives His bounties and favour.
Recite this dua'a after Fajr salat. It will keep you safe from all evils and misfortunes till next morning.

DU-A'A H'IFZ'I EEMAAN

It is our faith in one concise short dua'a Make your children learn it by heart as soon as they are able to pronounce bismillaahir rah'maanir rah'eem.
Recite this dua'a daily because it is a declaration of our faith, what we believe and whom we follow.
It brings countless blessings for us in this world; and on the day of judgement will serve us as PASSPORT TO PARADISE.

DU-A'A MI'-RAAJ

Allama Kafmi has written this dua'a in his book Misbah, on the authority of Imam Ali ibna abi Talib who learned it from the Holy Prophet.
The Holy Prophet said:
"Allah will have mercy on him who keeps this dua'a as a tawid, and recites it a great

deal. He will forgive his sins and the sins of parents and his children, bestow on him countless blessings, keep him safe from misfortunes, multiply his earnings, and cure his ailments."

Top improve and develop memory write the (Arabic) text of this dua'a on a clean piece of paper with saffron, wash it with pure water and drink it.

Hang the written (Arabic) text of this dua'a (like a tawid) around the neck of children to keep them safe from wild and poisonous animals, and the evil of witchcraft and jinn.

It is reported that at the time of mi-raj the Holy Prophet saw this dua'a written at the last post, qaaba qawsayn aw adnaa. The almighty Allah informed him that whoso recites this heavenly dua'a or keeps it written version on his person, will get countless blessings.

DU-A'A ILAAHEE KAYFA AD-O'OKA

Imam Ali bin Husayn Zayn al abidin is the author of this dua'a.

To get immediate acceptance of your supplication, in less time than the flash of an eye, recite this dua'a 100 times, preferably on Thursday, after praying 2 rakat salat, and 15 durood (salawat) before and at the end of this dua'a, and beseech the almighty Allah to fulfill your legitimate desires, wants and needs.

DU-A'A NOOR

It is reported in Muhaj al Dawat by sayyid bin Tawus that bibi Fatimah Zahrah taught this dua'a to Salman. The Holy Prophet had given this dua'a to his daughter with instruction that whoso recites it daily, in the morning and evening, remains safe from fever.

DU-A'A NAADI ALI

It is reported through reliable sources that when all the notable companions of the Holy Prophet failed to make headway at Khaybar, Jibrail came with the text of Naadi Ali and asked the Holy Prophet to call Ali through this. The Holy Prophet accordingly recited this divine revelation, and Mawla Ali who was staying at home because of an eye infection, came and conquered the fort of Khaybar.

Naadi Ali, both large and small, are very affective for all purposes, particularly to overcome enemy, to come through tight situations, to withstand crises, to avoid accidents, and to have freedom from danger.

It is also recited from sufficient means of livelihood, for prosperity and overall welfare.

In the battlefield warriors recite Naadi Ali to get better of the attacking opponents.

To bring an important and urgent task to successful completion recite it 7 times.

Recite 18 times over a glass of water and drink it to cure any type of disease.

Before going to meet a person or a group of persons who hold the key to your problem recite it three times, insallah, the outcome will be in your favour.

Recite it 20 times if you want your debts to repaid within reasonable time.

Recite it 10 times daily if you are childless and desire to have a child.

Keep a glass of water in front of you. Recite 5 times and make the expectant mother drink the water. The delivery will be easy and painless.

A sure protection against enemies and misfortunes if it is written on paper and put

on the right arm.

THE VIRTUE OF DUA YA MAN AZHAR AL JAMEEL

Here the Holy Prophet (SAW) said to Gabriel: What is the virtue of these words? Gabriel said: Far away! Far away! It is something impossible, for if the angels of seven heavens and seven earths gather to describe its virtues till the Day of Judgment, they are not able to describe a single part of it."

"Therefore when a man says: O You who reveal the beauty and conceal the ugly, God covers up his defects and has mercy on him and makes him look beautiful on the Day of Judgment and covers his defects with a thousand veils in the world and the hereafter."

"And when he says: O You who do not take the wrongdoer to task and do not tear the veil, God will not take him to task on the Day of Judgment and on the day all veils are torn, God will not tear his veil."

"And when he says: O You who are Great Forgiver, God will forgive his sins even if they are as much as the sea foam."

"And when he says: O You are of great forbearance, God will forgive him such sins as theft, drinking wine, and other sins."

"And when he says: O You who have pardon abounding, God will open seventy gates of Mercy to him in a way that he will be overwhelmed by God's Mercy till he dies."

"And when he says: O You who have opened Your hands for mercy, God opens His hands of Mercy to him."

"And when he says: O Hearer of all whisperings, O You to whom all complaints are made, God will give him rewards as many as given to every afflicted and unaffiliated, every losing and sick as well as destitute and every one affected by calamity till the Day of Judgment."

"And when he says: O Possessor of great favor, God will make him noble as prophets."

"And when he says: O You who give blessings to Your servants when they do not deserve it, God will grant him rewards as many as the number of those who have thanked His blessings."

"And when he says: O our Master, O our Lord, God will say: My angels! Be witness that I forgave him and I will give him rewards as many as those being in paradise and Hell, the seven heavens and the earths, the sun, the moon, the stars, drops of rain, sands mountains, dews and throne."

"And when he says: O our Guardian, God will make his heart replete with faith."

"And when he says: O the Goal of our desires, God will give him the love of all creatures on the Day of Judgment."

"And when he says: I beseech You O God not to make my being ugly with Fire, God will say: My servant has asked Me to free him from Fire. O My angels! Be witness that I set him, his parents, his brothers, his household, his children and his neighbors free from the Fire and accepted his intercession for a thousand others who deserved the punishment by fire and saved them from it."

"O Muhammad! Teach this Dua only to men of piety. Do not even teach it to hypocrites, for it is a Dua which God will answer. This is the Dua recited by the men of Beite Ma'moor (an edifice in the fourth or seventh heaven as sacred as Ka'aba) when they circumambulate it."

APPENDIX III

LIST OF ITEMS NOT TO FORGET (You will know why when you arrive!!!)

- Sweater or fleecy type jacket
- Powdered Gatorade
- Dextrose (energy candy)
- Waterbottle to drink from
- Waterbottle to take to the bathroom
- Tissue packets or a handkerchief
- Pen and Paper to write notes and thoughts with.
- Rolls of Toilet Paper
- Garbage Bags
- Small Plastic bags
- A permanent marker
- If you get cold at night a hot water bag!!!
- Wuzu mini towel (hand towel)
- Warm Sleeping Bag (don't be cheap in this purchase)
- Travel pillow
- Duck or packing tape
- Masking Tape
- Flashlight to find your stones in Muzdalifah!
- Safety Pins
- A needle and thread kit!
- Scissors
- An extra shoulder bag for all the shopping you will do!
- Purchase a small shoulder bag to take with you in haram to put dua books in, tasbeeh etc.
- A small backpack or duffle bag for Mina and Arafat!

- An MP3 player to listen to duas inside haraam (you have to download the duas yourself!!!!)
 - Dua Joshan Al-Kabeer
 - Dua Tawba
 - Dua Mashlool
 - Ziarat e Ashura
 - Dua Kumayl
 - Dua Ahad
 - Dua Faraj
 - Dua Tawba
 - Dua Abu Hamza Thimali
 - Ziarat e Aaleyasin
 - Dua Mojeer
 - Dua Semat
 - Dua Arafat
 - Ziarat of Baqi
 - Dua Iftitah
 - Dua Tawassul
 - Hadith e Kissa
 - Dua Makarimul Akhlaq
 - Munajaat of Imam Ali
 - Dua Nudbah
 - Dua Sabah
 - Ziarat Jamia
 - Ziarat Waritha
- Alarm Clock or digital watch
- Small quran
- Batteries

Food:

- Chips (Pringles work best)
- Granola Bars
- Chevro and Gantya (for those midnight snacks)

Medication:

- Imodium (for stomach)
- Tylenol or Advil
- Bandages
- Polysporin or Ozonol
- Vitamin Multi-Caps
- Halls (Vitamin C)
- Lotions (Vaseline)

Namaz-e-Shab:

List the 40 people you would like to pray for in the sacred Namaz Layl:

- 1) Mohamedhusein Ladak and Family
- 2) _____
- 3) _____
- 4) _____
- 5) _____
- 6) _____
- 7) _____
- 8) _____
- 9) _____
- 10) _____

- 11) _____
- 12) _____
- 13) _____
- 14) _____
- 15) _____
- 16) _____
- 17) _____
- 18) _____
- 19) _____
- 20) _____
- 21) _____
- 22) _____
- 23) _____
- 24) _____
- 25) _____
- 26) _____
- 27) _____
- 28) _____
- 29) _____
- 30) _____
- 31) _____
- 32) _____
- 33) _____
- 34) _____
- 35) _____
- 36) _____
- 37) _____
- 38) _____
- 39) _____
- 40) _____

Duas and Hajjat:

It is always a very good idea to remember those individuals who asked you to pray for them in the house of the almighty. Unfortunatley, when our call is answered by Allah, we are so overwhelmed with emotion, that we forget key individuals. Thus, take the time to write their names down. When one prays for others, their own hajjats are accepted because the angels are now praying for them because they remembered others before praying for themselves.

Don't forget to include the following in your hajjats as well:

- Pray for the health and safety of our beloved 12th Imam.
- Pray for his quick return and that we can help him as he establishes the true and rightful government.
- Pray that we are able to see his face and are guided everyday by his light.
- Pray that he helps us in increasing our iman.
- Pray that on the day of resurrection, he will come and intercede on our behalf.
- Pray for the safety of all the marajah in Iraq and everywhere around the world.

- Pray for those who do not have jobs, to earn a form of living so that they may help in spreading the word of Islam.
- Pray for the ones who do not have children, that the almighty grants them and their families children who base their lives on the sunnah of the prophet and his immaculate household.
- We pray for the victims in Pakistan, Iraq, Afghanistan and everywhere else around the world who are currently facing hardships.
- We pray for all the individuals who are ill, that you the almighty grant them great health.
- We pray that for all the individuals who are currently not married, that you find them a spouse quickly.
- We pray to you the most generous, that ones who are less fortunate, that you grant them ease of their hardships.
- We pray for all individuals who have not had the opportunity to visit your holy house, that you respond to their call, and accept their call.
- We pray for all the momineen who have passed away, that you grant them ease in the sufferings of the grave.
- We pray to you the almighty that you give all Shia Muslims in the world to have the opportunity to visit the holy shrines of Imam Hussein and the rest of the Imams so that we are able to pay our respects to them.
- We pray to you, the most kind and compassionate, that you give us the opportunity to come visit you next year and every year after that. And for those who haven't had the opportunity to come, please grant them this wish.
- WE pray for the following:
 - That you give us Yaqin in our hearts.

- That you give us Barakat in Rizq.
- We pray that all the individuals who asked us to pray on their behalf, that you grant them all their wishes and desires.

BIBLIOGRAPY

The Holy Quran

Nahjul Balagha, Translated by Askari Jafery.

Hajj in the Words and Message of Imam Khomeini. By the Institute for compilation of the works of Imam Khomeini (International Affairs Department)

Secrets of Hajj. By Ayatullah al Hajj Shaykh Husain Mazaheri. Translated by Saleem Bhimji

Hajj – The Islamic Pilgrimage. By Sayyid Mohammed Zia Abadi. Translated by: Ali Akbar Aghili Ashtiani

Hajj (The Pilgrimage). By Dr. Ali Shariati. Translated by: Ali A. Behzadnia, M.D. & Najla Denny

Lectures on Hajj (Islamic Law at ICAS). By Ayatullah Sayyid Fadhel Milani.

The Spiritual Aspects of Haj: In the Qur'an and Sunnah